

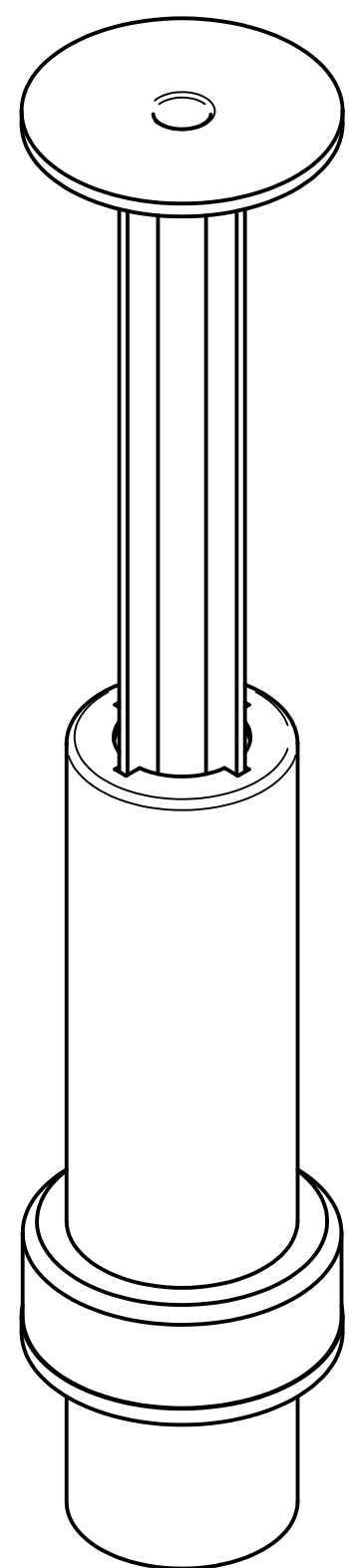

REVISION HISTORY

REV	DESCRIPTION	DATE

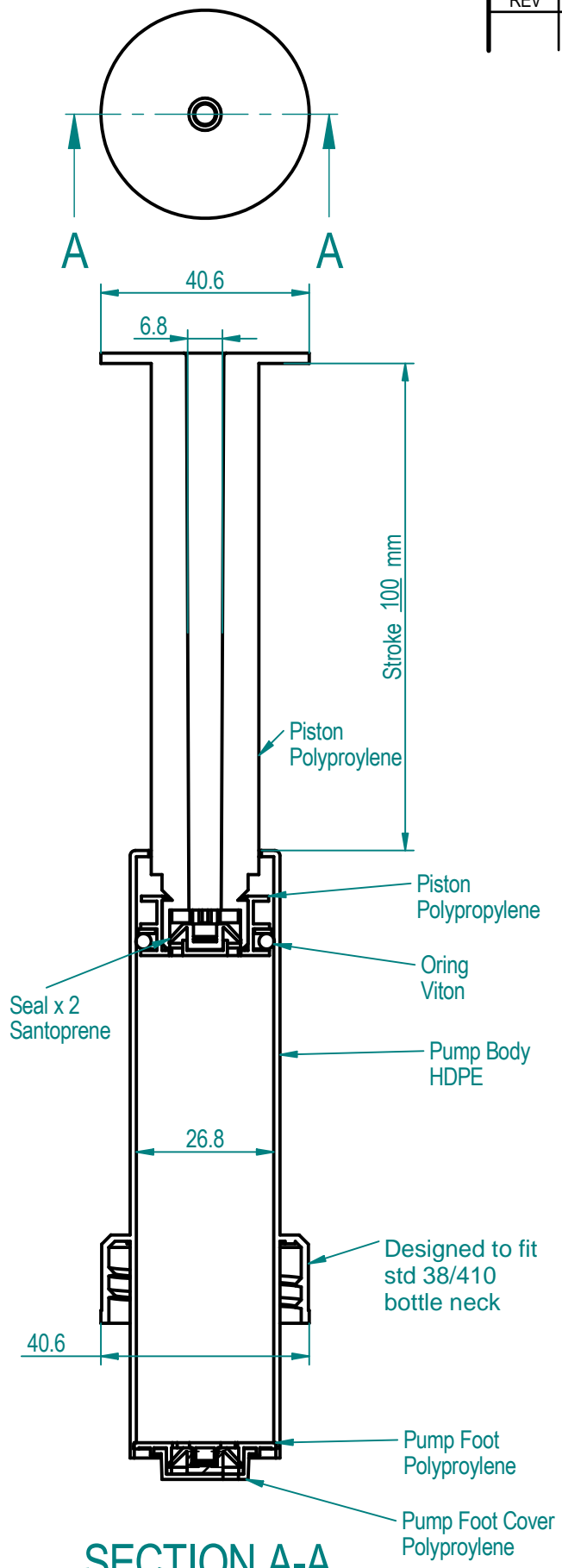

UNLESS OTHERWISE SPECIFIED
DIMENSIONS ARE IN MILLIMETERS
ANGLES $\pm X.X^\circ$
2 PL $\pm X.XX$ 3 PL $\pm X.XXX$

DRAWN	DATE	
NAME John	14/Sep/20	
CHECKED		TITLE
SCALE	SHEET 1 OF 1	Disposable Vacuum Pump
SIZE A4	FILE NAME: Complete.dft	REV 1